

RESIDENTIAL ROOFING REPLACEMENT

- This handout is intended only as a guide. It shall not be considered a complete set of requirements
- All materials and the installation of all materials must comply with the 2020 Minnesota State Residential Code and the manufacturers' installation specifications for each product.
- **VALID** for single-family homes, duplexes, and townhomes. (Does NOT include condominiums, apartment complexes, and commercial properties.)
- **NOT VALID** for repairs, replacement, removal, or installation of any structural members
- Each address requires a separate permit.

PERMIT CARD (throughout the project) shall be:

POSTED prior to start of work - **VISIBLE** from street or driveway - **ACCESSIBLE** to the inspector

INSPECTION REQUIREMENTS:

- Inspections **MUST** be scheduled during office hours **AT LEAST** one business day prior to inspection. If a specific date and time is required, additional notice may be needed. Failure to cancel a scheduled inspection may result in a reinspection fee.
- **Office Hours:** Monday-Friday • 8:00 a.m. - 4:30 p.m.
- **Phone:** (952) 442-7520 or (888) 446-1801

Inspections: (Refer to your permit card regarding project-specific inspections)

- **In-Progress Inspection:** Call to schedule after completing the following:
 - Old roof covering is torn off.
 - Ice barrier and underlayment are applied but not yet covered by new roof covering.
 - Roof Ventilation Worksheet is filled out.
 - Installation instructions are on site.
 - Verification of roof covering compliance with applicable material standards is on site.
 - Your representative must be on site, able to communicate with the inspector, and provide access to the roof (ladder).
- ❖ ❖ In the event that an inspector is unavailable for an In-Progress inspection, MNSPECT will notify you via email of our picture requirements.

NOTICE: Construction or work for which a permit is required shall be subject to inspection by the Building Official, and such construction or work shall remain accessible and exposed for inspection purposes until approved. It is the responsibility of the permit applicant to be in attendance on site and provide access to the Building Official for all required inspections. If work is concealed and/or work is not complete at time of inspection, an additional inspection is required, and a reinspection fee may apply.

Note: The State of Minnesota requires that all residential building contractors, remodelers, roofers, plumbers, and electricians obtain a state license unless they qualify for a specific exemption from the licensing requirements. (326B.805) Any person claiming an exemption must provide a copy of a Certificate of Exemption from the Department of Labor & Industry to the Municipality before a permit can be issued.

Note: To determine whether a particular contractor is required to be licensed or to check on the licensing status of individual contractors, please call the Minnesota Department of Labor & Industry at 651-284-5034.

Note: For specific code requirements, please contact the Building Inspection Department at 952-442-7520 or 888-446-1801 or e-mail: info@mnspect.com.

When new roof covering is to be installed over one layer of existing covering, an initial inspection prior to covering will need to be completed to verify that only one layer is being covered and compliance with R908.3.1 is being met:

R908.3.1 Re-covering versus replacement. New roof coverings shall not be installed without first removing all existing layers of roof coverings where any of the following conditions exist:

1. Where the existing roof or roof covering is water-soaked or has deteriorated to the point that the existing roof or roof covering is not adequate as a base for additional roofing.
2. Where the existing roof covering is wood shake, slate, clay, cement or asbestos-cement tile.
3. Where the existing roof has two or more applications of any type of roof covering.

A re-inspection and re-inspection fee will be required if the original roofing is determined to be inadequate.

PROJECT CHECKLIST:

The following is a guideline to assist in compliance with the requirements of the MN State Building Code.

- All removed and excess roofing materials must be disposed of at an MPCA-approved landfill.
- Identify the roof pitch(es) to determine which approved roof covering(s) can be installed

Roof Covering	Pitch Requirements	Roof Covering	Pitch Requirements
Asphalt Shingles	2" rise per 12" run or greater (▲★★)	Metal Roof Panels (lapped, with sealant)	½" rise per 12" run or greater
Clay/Concrete Tile	2½" rise per 12" run or greater (★★)	Metal Roof Panels (standing seam)	¼" rise per 12" run or greater
Wood Shingles/Shakes	3" rise per 12" run or greater (▲★)	Modified Bitumen Roofing	¼" rise per 12" run or greater
Metal Shingles	3" rise per 12" run or greater (▲★)	Thermoset Single-ply Roofing	¼" rise per 12" run or greater
Metal Roof Panels (lapped, no sealant)	3" rise per 12" run or greater	Thermoplastic Single-ply Roofing	¼" rise per 12" run or greater
Slate Shingles	4" rise per 12" run or greater (▲★)	Liquid-applied Coatings	¼" rise per 12" run or greater
Mineral-surfaced Roll Roofing	1" rise per 12" run or greater (▲★)	Sprayed Polyurethane Foam Roofing	¼" rise per 12" run or greater

Sheathing

- Make sure the roof decking is in good condition and there are no gaps that exceed the manufacturer's installation instructions for the roof covering used; Roof sheathing shall be checked prior to re-roofing and repaired or replaced if rotted or unsound. Replacement sheathing shall conform to the requirements of the Building Code and the manufacturer of the product.
- Sheathing shall be 1x boards with gaps no greater than the shingle manufacturer's installation instructions allow (no more than ¼" gap) or solidly sheathed with wood structural panel sheathing (1309.R905.1.2).
- Obtain a Building Permit if any structural members need to be repaired, replaced, and/or added.

Flashing

- Flashing is required whenever a roof plane intersects with a wall, chimney, or other vertical member. Flashing should be at least 4" up the sidewall, and project at least 4" on to the roof material (1309.R905.2.8.3).
- Where siding is provided on the vertical sidewall, the vertical leg of the sidewall flashing shall be installed under the sidewall building wrap and siding.
- Continuous flashing should be used where a wall intersects the roof and the roof falls away from the wall (dormer).
- Step flashing should be used where a roof intersecting the wall descends along the wall line (sidewall). If the flashing is not installed behind the siding (stucco/brick) counter flashing must be used. If Reglet flashing is used, it must be cut into the wall and properly sealed at the top.
- Make sure all flashing is constructed of a minimum 26-gauge, corrosion-resistant sheet metal.
- Install valley linings and flashing.
- A cricket or saddle is required on all chimneys or penetrations that are more than 30" wide (measured parallel to ridge). See Figure R1003.20 and Table R1003.20 – 2020 MN State Residential Code.

Underlayment

- ▲ Install the required ice barrier starting at the eaves to a point **no less than 24” inside the interior of the exterior wall** (measured horizontally). If there are step-backs in the walls (at an entryway door) that area may require additional coverage (1309.R905.1.2).
Exception: detached structures that are not heated.
- Underlayment shall comply with ASTM D226, D1970, D4869, and D6757 and shall bear a label indicating compliance with those standards.
- ★ Install the required underlayment materials, ensuring the underlayment materials extend to the edges of the roof deck. ***(For Asphalt Shingles - Roofs with pitches of 2:12 up to, but not including, 4:12 have double underlayment requirements. First, apply a 19” strip along the eave, and then 36” strips lapped a minimum of 19”. End laps shall be 4” and offset by 6’. Please call if you need additional information.)**

Roof Covering

- Asphalt Shingles must comply with ASTM D3161 – Class D or F; or ASTM D7158 – Class D, G, or H (1309.R905.2.4.1).
- Ensure all roof covering materials are installed in accordance with the manufacturers’ installation instructions.

Fasteners

- Shingles must be attached using nails only (1309.R905.2.5).

Ventilation

- Ensure all venting terminations extend through the roof deck and are properly flashed.
- Ensure the minimum attic cross-ventilation is provided.
How to calculate the minimum required attic ventilation:
 1. When soffit/eave venting is provided, 1 sq. ft. minimum of net free ventilation area shall be provided for every 300 sq. ft. of attic area (40%-50% of the net required ventilation opening must be located in the upper portion of the roof, no more than 3’ below the ridge). The remaining ventilation must be located in the eave/soffit.
 2. When less than 50% of the required ventilation is provided in the eave/soffit, 1 sq. ft. minimum of net free ventilation area shall be provided for every 150 sq. ft. of attic area.

Finishing

- Asphalt shingles will not seal if they cannot lay flat. If the shingles have been laid too tight, where the edges raise up where they meet, those shingles will never seal and will be a point of failure in a high-wind event.
- If there is evidence of exposed fasteners or nails driven at an angle, the installer will be required to correct the installation.

Address: _____

RESIDENTIAL ROOF VENTILATION WORKSHEET

MN Rule 1309.R806.2 Minimum vent area. The minimum net free ventilating area shall be 1/150 of the area of the vented space.

- 1) **Total Roof Area** $W \times L = \text{Roof Area}$ Do this for all roof areas and combine for Total Roof Area. **TRA = _____ ft²**
 2) **Ventilation Area** $TRA / 150 = \text{Roof Ventilation Area (RVA)}$ **TRA _____ divided by 150 = RVA = _____ ft²**
 3) **Ventilation Requirements** Roof Ventilation:

Type: _____ Make and Model: _____ Net Free Area (NFA): _____ per vent or linear foot

$RVA \text{ ft}^2 / NFA \text{ ft}^2 = \text{vents or feet}$

RVA _____ divided by NFA _____ = _____ vents or feet

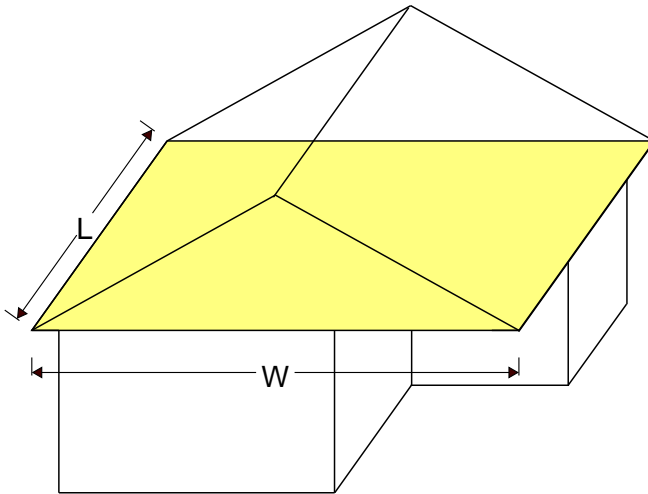

To use the 1:300 rule, you must confirm the following:

A class I or class II vapor retarder is installed to the warm in winter side of the ceiling assembly:	Yes	No
Roof intake Net Free Area is functional and provides 40-50% of Roof Ventilation Area (RVA):	Yes	No

- 1) **Total Roof Area** $W \times L = \text{Roof Area}$ Do this for all roof areas and combine for Total Roof Area.
 2) **Ventilation Area** $TRA / 300 = \text{Roof Ventilation Area (RVA)}$ **TRA _____ divided by 300 = RVA = _____ ft²**
 $RVA / 2 = \text{Exhaust Ventilation Area (EVA)}$ **RVA _____ ft² / 2 = EVA = _____ ft²**

- 3) **Exhaust Vent Requirements** Roof Ventilation:
 Type: _____ Make and Model: _____ Net Free Area (NFA): _____ per vent or foot

*If Net Free Area is expressed in in², continue to step 4.

Convert Net Free Area in² to ft² by dividing in² by 144.

NFA _____ in² / 144 = NFA _____ ft²

- 4) **Total Exhaust Ventilation Required** (with 3' of Roof Peak)
 $EVA \text{ ft}^2 / NFA \text{ ft}^2 = \text{vents or feet}$ **EVA _____ divided by NFA _____ ft² = _____ vents or feet**